

# HUSSMANN®

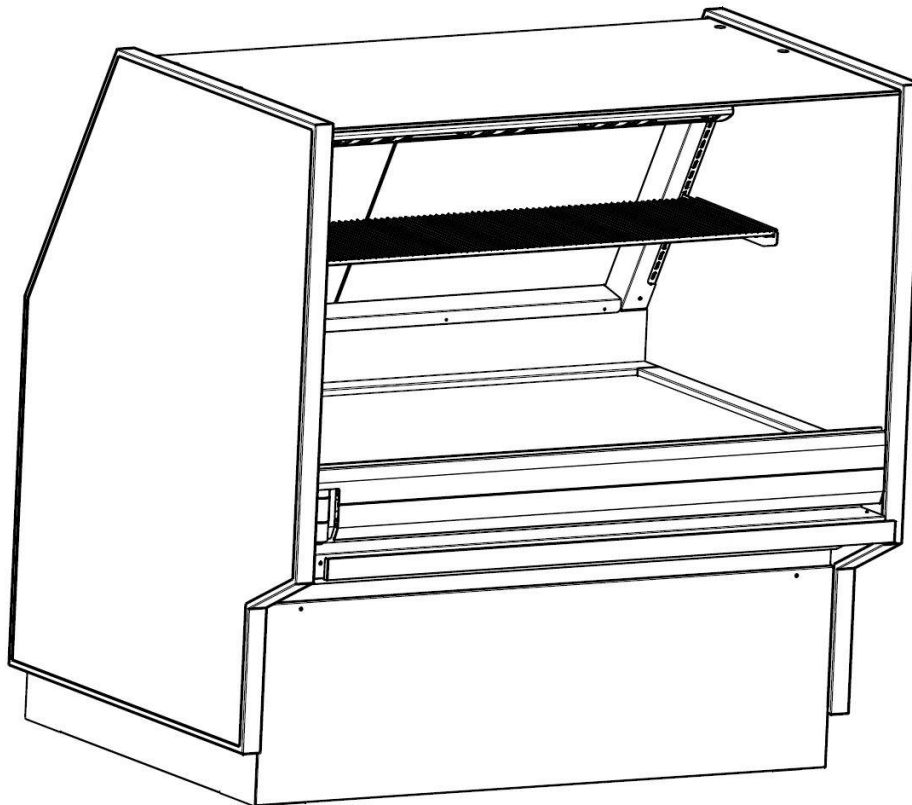

## **DH13 - 1 SERIES – SERVICED HOT FOOD INSTALLATION MANUAL: IM-014**

Standard versions  
The following models are covered by this Manual

**DH13**

66 Glendenning Road, Glendenning NSW 2761  
PO Box 42 Doonside NSW 2767  
t: +61 2 8805 0400 f: +61 2 9675 2897

# Contents

<b>Pre-installation</b>	<b>2</b>
Important Safety Instructions	2
Case services dimensions	3
Operating environment	4
Handling and transporting cases	4
Shipping damages and shortages	4
<b>Installation</b>	<b>5</b>
Positioning and levelling	5
Joining the cases	8
Attaching kick plates	9
Connecting power supply	11
Installing sensor probes	11
Mounting fixtures	12
<b>Commissioning</b>	<b>13</b>
Cleaning case	13
Starting up	13
Start-up checks	13
<b>Decommissioning</b>	<b>13</b>
<b>Disposal</b>	<b>13</b>
<b>Operation</b>	<b>14</b>
Loading Merchandise	14
Cleaning and Maintenance	14
Daily Checks	14
Cleaning	15
Important Notes	15
Cleaning Procedure	15
Six Monthly Maintenance	16
Operation Servicing	16
<b>Troubleshooting</b>	<b>17</b>
<b>Appendixes</b>	<b>18</b>
Appendix 1      Wiring diagrams	18
Appendix 2      Produce Engineering Datasheets	18
Appendix 3      Setting table	18
Appendix 4      Attaching case ends	18
Appendix 5      Top glass horizontal adjustment	20
Appendix 6      Front glass camber adjustment	22
Appendix 7      Risk analysis	23
Appendix 8      Controller	24
Appendix 9      Warranty	25

# Pre installation

## Important Safety Instructions

Please read the user manual carefully and store for later reference. In this document you will see these symbols with following meanings

**NOTE**

Information in this manual is to be followed in conjunction with specifications, work practices and regulations of the customer, installing company and relevant industry.

**CAUTION**

Care must be taken to avoid damage to drainage outlets and electrical equipment mounted under or at the rear of cases.

**CAUTION**

This symbol indicates electrical safety must be concerned

**WARNING**

- Leave enough space to install the system. The space requirement will be instructed in "Pre-installation" section.
- Before installing the system make sure the power source is accessible to the cases array.
- All the power source has to be properly earthed.
- If any potential fail or product disconformity is investigated, please consult a qualified service technician.
- Always disconnect the power of the cases before conducting any service or maintenance.
- Keep the case out of direct sunlight, fire hazardous environment, or high moisture or humidity area.
- Fail to install the system as instructed in this manual may void Hussmann Warranty.

### Case Services Dimensions

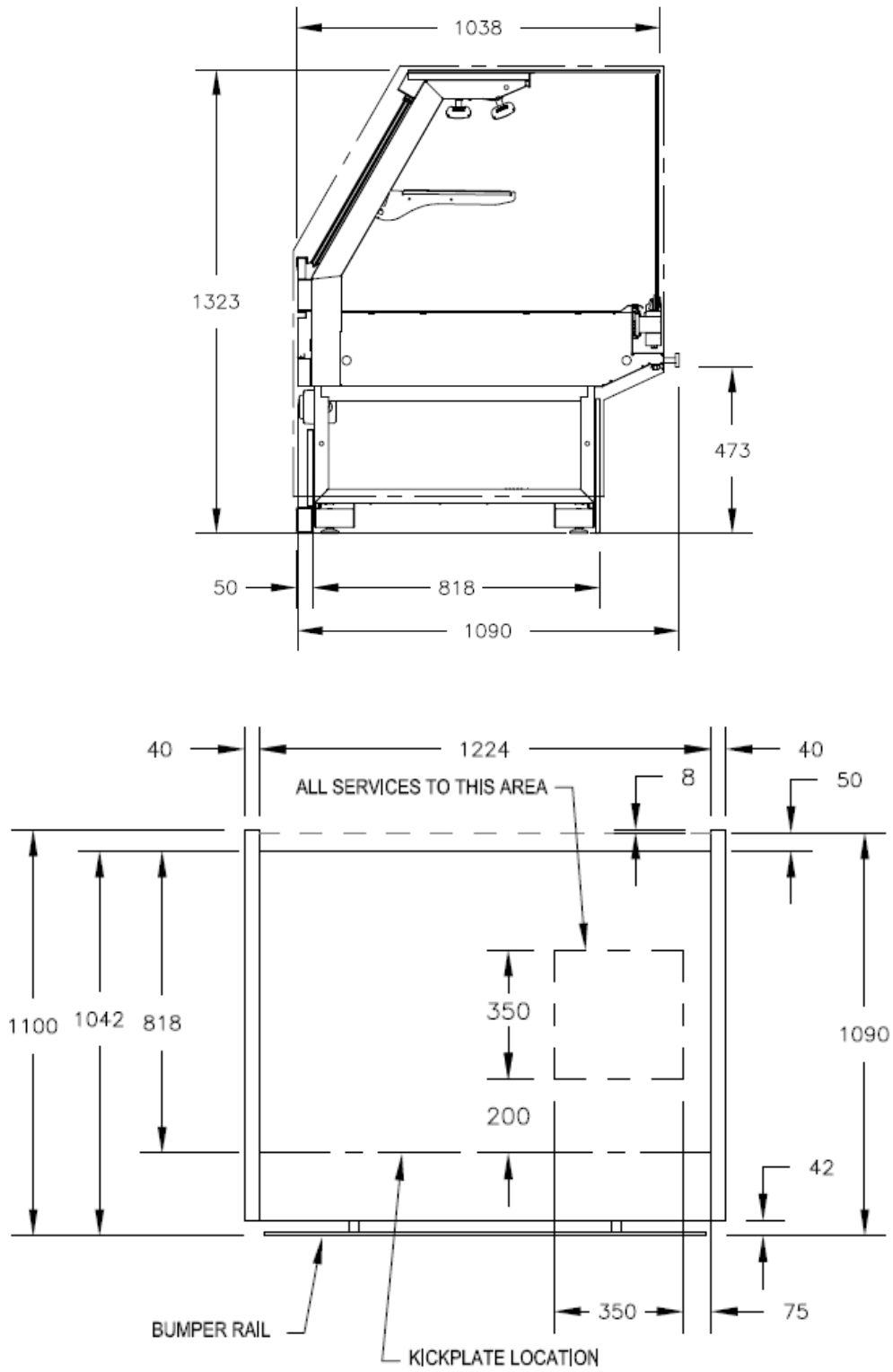

Fig (1) Service layout standard depth case

## Operating Environment

All Hussmann Cases have been factory tested to AS1731, 25°C at 60% RH. Hot food display cabinet is also tested to AS4322.

Cases must not be positioned in areas that may be subject to cold or air currents such as ventilation ducts, open doors or windows, direct sunlight, electric fans or ovens, etc. Otherwise the cabinet may show poor temperature performance or the operating life is affected.

**NOTE**

Refer to product MSDS for all hazardous substances used during installation in relation to their application, PPE, first aid, disposal and emergency management. Refer page 20 (Risk Analysis)

For MSDS sheet contact your Hussmann Representative

## Handling and Transporting cases

Case dimensions can be found in the product engineering data sheets.

(This manual is a guide only. Always refer to the latest case information available from Hussmann Customer Service)

Always ensure that the moving device is of a suitable type, and has sufficient lifting capacity for the case weight and dimension. Always lift cases from the underside.

Refer to and follow the manual handling policies of your Company when moving cases.

**CAUTION**

Care must be taken to avoid damage to drainage outlets and electrical equipment mounted under or at the rear of cases.

## Shipping Damage and Shortages

If possible, it is recommended that packaging be removed from the cases before they are moved into the store.

After removing packaging, inspect the case for any shipping damage and ensure that all case inclusions, such as trims etc are accounted for. Immediately report any shipping damage to the carrier and inform Hussmann Customer Service of any short supplies.

# Installation



**NOTE**  
 Information in this manual is to be followed in conjunction with specifications, work practices and regulations of the customer, installing company and relevant industry.

## Positioning and Levelling

Each case has a unique identification number as follows:

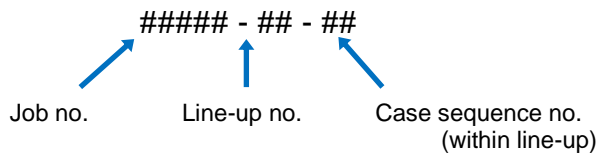

Example: **106076.42.4** identifies this case in the 4<sup>th</sup> sequence of the line 42 for the job 106076.

As well as on the packaging, the case identification number appears as a serial number on the rating plate (most commonly located on the ceiling panel left hand end of the case) refer to Fig (3) and is printed on a decal on the rear of the case ref Fig (4). The case sequence number is also written on a ticket on the front panel.

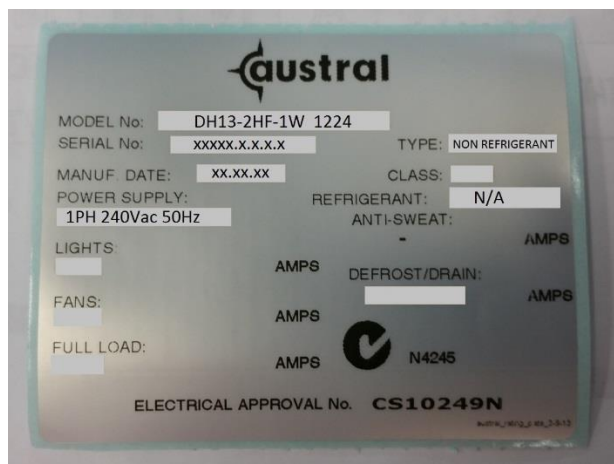

**Fig (3) Rating Plate**



**Fig (4) Decal rear of case with case sequence number**

Cases must be positioned so that line-up numbers and case sequence numbers run in succession left to right standing in front of the cabinet.

**CAUTION**

Ensure the lifting capacity of the trolley, etc. is sufficient for the case. Refer to the product engineering data tables and Risk Analysis (page 20).

To position the cases:

1. If the plinth surface is level, position the case designated as line up number 1 and case sequence number 1 in the required position.
2. If the plinth surface is not level, determine where the highest point of the plinth is, and position the case allocated to this position first.
3. Adjust the case height using the adjustable feet (if fitted) or metal shims (do **NOT** use **timber**) to ensure the case is level to **within +/- 1.5mm** from front to back and side to side and chassis of case is **NOT twisted**. Maximum 25mm adjustment.

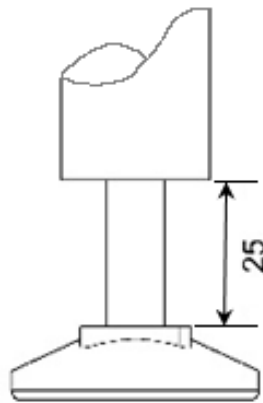

Fig (5) Levelling feet adjustment

**NOTE**

It is important that all cases are level for correct case joining and operation. If cases are not properly levelled and positioned, door misalignment will be evident, resulting in the job needing to be redone at complete cost to the installer.

**Husmann is not liable or responsible for the cost involved in fixing problems arising directly from the installers' failure to follow the requirements outlined in this manual.**

**DO NOT SET CASE LEVELS OFF THE PATCH END** fitted to a case.

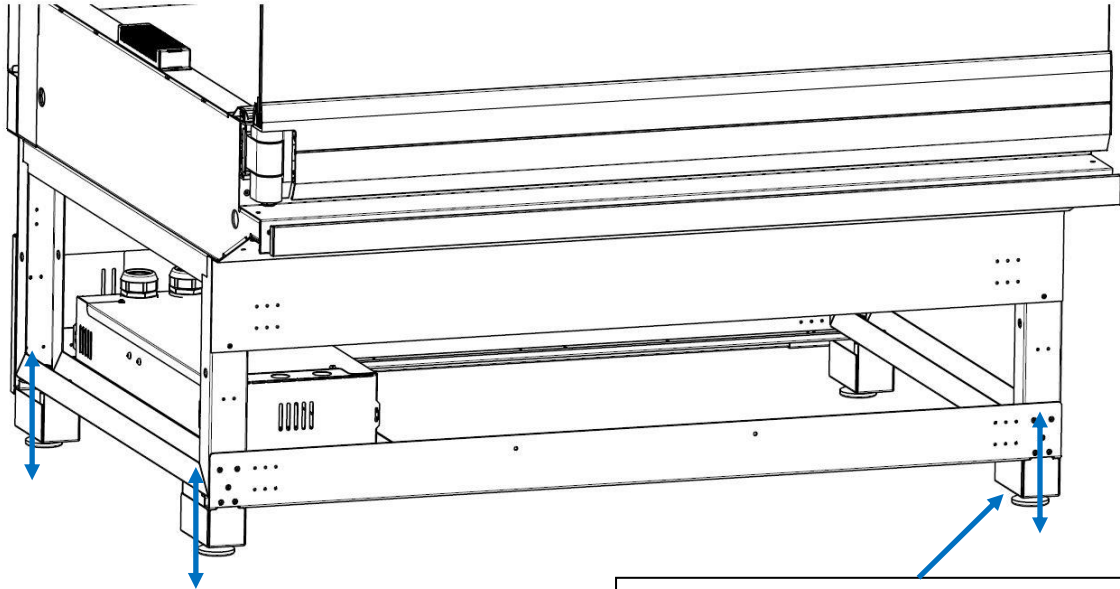

Make sure case is level:  
Front to Back: +/- 1.5mm  
Side to Side: +/- 1.5mm

Make sure **all** adjusting feet, NOT just the ones at the end of the case, are adjusted firmly to ensure case does not sag

Fig (6) Case Levelling

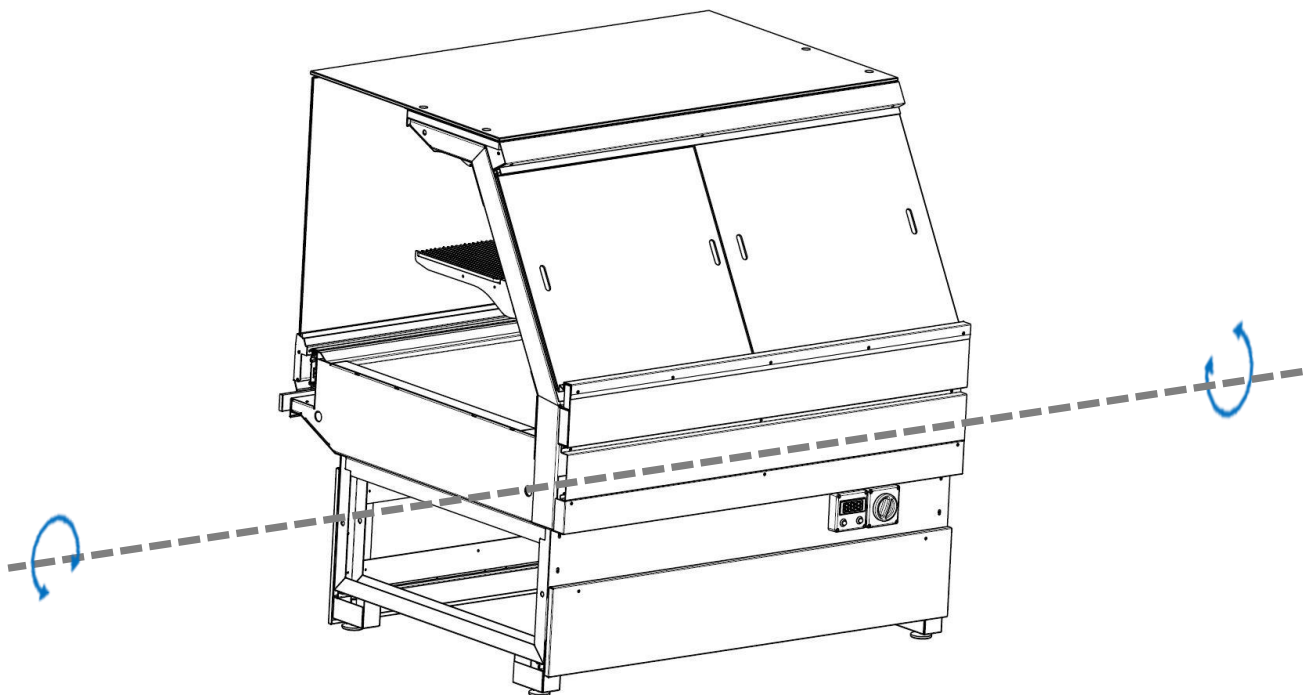

Make sure Chassis of case is **NOT TWISTED**.

Fig (7) Case twisting



## Joining the Cases

Ensure cases are sealed before joining them to other cases

For instructions on attaching case ends, refer to appendix 4: attaching case ends

**CAUTION**

Do not walk or sit on cases.

To join the cases

1. Draw up the required case tightly against the case already in position

**CAUTION**

Case joining bolts should only be used, with care, at the final pulling-up stage.

2. Ensure that the case is level, from front to back and side to side, with the existing case.
3. Insert the joining bolts, found in the blister pack, into the end holes and tighten – see Fig (9): joining hole locations

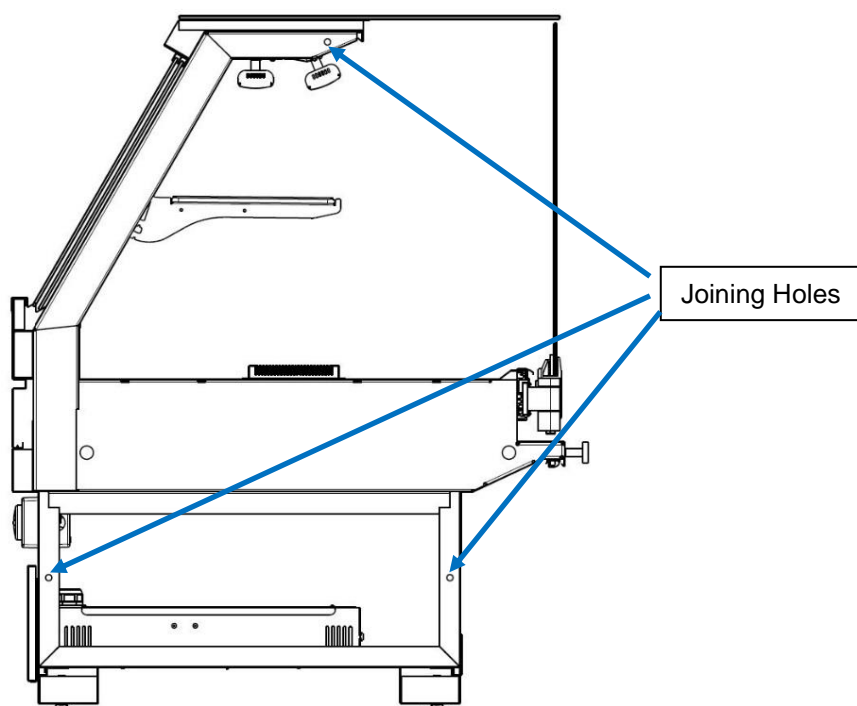

**Fig (9) Joining holes location**

## Attaching Kickplates

(This should be done after final Installation of Refrigeration and Drainage connections)

Attach kickplates and, if required, silicon seal to the floor once installation is complete and drains checked for water leaks.

### Front Panel

1. Attached front panel and align with front skid rail refer figure 10.
2. Push front panel into bottom and top clips.
3. Check front panel is securely in position.

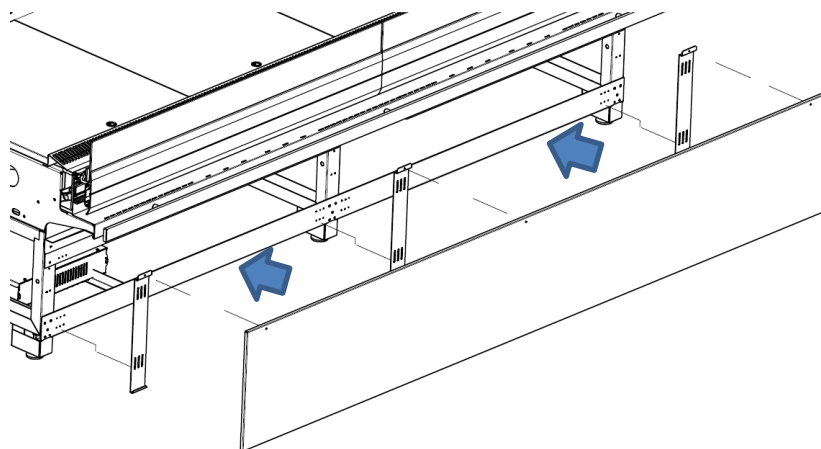

Fig (10) Attached front panel

### Back Panel

1. Attached back panel and align with back skid rail refer figure 11.
2. Push back panel into bottom clip and over top clips.
3. Check back panel is securely in position.

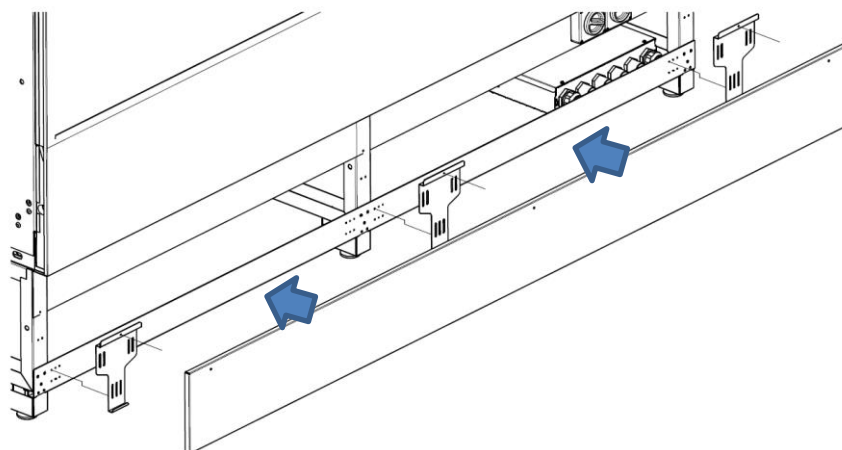
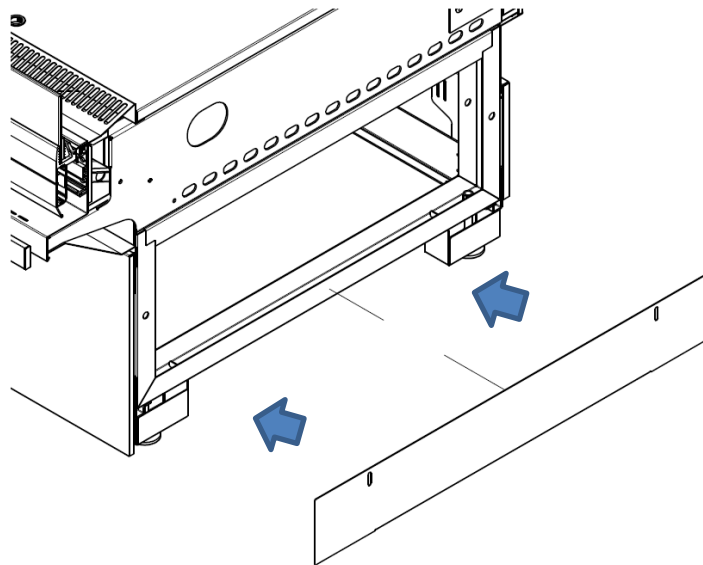

Fig (11) Attached back panel

## Side kickplate

1. Attached side kickplate as per drawing refer figure 12.
2. Adjust slot in kickplate to suit. Make sure kickplate is above floor.
3. Screw kickplate in position.
4. Check kickplate is securely in position.



**Fig (12) Attached side kickplate**

## Connecting Power Supply

- The appliance must be installed so the power is accessible.
- To ensure that the appliance is not accidentally switched off, connect unit to its own power source. Do not connect any other appliance using this source
- Size the cable according to AS3008 or relevant local standards. For power rating please refer to product engineering datasheet for details.

Ensure the appliance is properly grounded (earthed).

## Installing Sensor Probes

The DH13 range of cases have the probes pre fitted at the factory. Probe location as per Fig 14



### CAUTION

Refer to relevant State or Territory legislation relating to safe working heights.

Probe location:

1. 2 x Probe connected to rear of case.

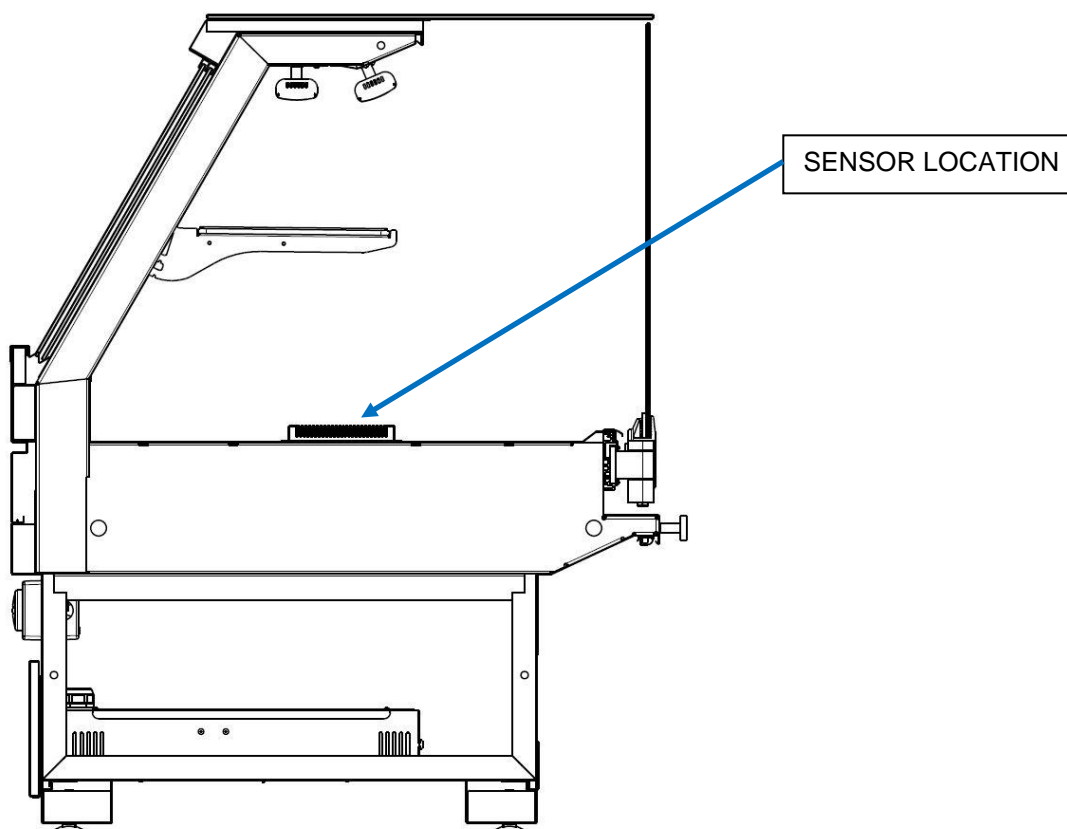

Fig (14) Location of probe

**CAUTION**

Do not walk or sit on cases.

**Mounting fixtures**

Replace racks and shelves etc, as necessary to store requirements

**NOTE**

Incorrect pan and display tag configurations may compromise case performance.

# Commissioning

## Cleaning case

1. Remove the PVC protective coating on stainless steel, where applicable
2. Remove any residue, silicon or tape marks with a cloth moistened with rubbing alcohol
3. Remove all debris from in and around the case
4. Wipe case with a clean, damp cloth, if necessary

## Starting up

1. Check supply power is ready and correct voltage. (by Licensed Person)
2. Confirm correct operation of RCD (if fitted) (by Licensed Person)
3. Turn case power on

## Start-up checks – (by qualified persons only)

1. Check that all lights (and light RCDs, if installed) are working correctly.
2. Check the thermostat is set correctly (If installed).
3. Approximately 2 hours after start-up, check that the case is at correct operating temperature (refer the Product Engineering Data).

# Decommissioning

Plan and risk assess the decommissioning process to include the following:

1. Isolate the case from electrical systems. (Disconnection is to be undertaken by qualified persons only).
2. Removal of the case is to be in the reverse order of installation listed previously.

# Disposal

Case disposal is to be carried out by the following:

1. Metal component removed and recycled
2. Remaining by commercial waste management

# Operation

## Loading Merchandise

Cases should only be stocked with merchandise for which they were manufactured as indicated by the case model number on the rating plate (see Fig (15): Rating Plate) that is typically located, on the rear back panel at the lower right hand end as viewed by the operator.

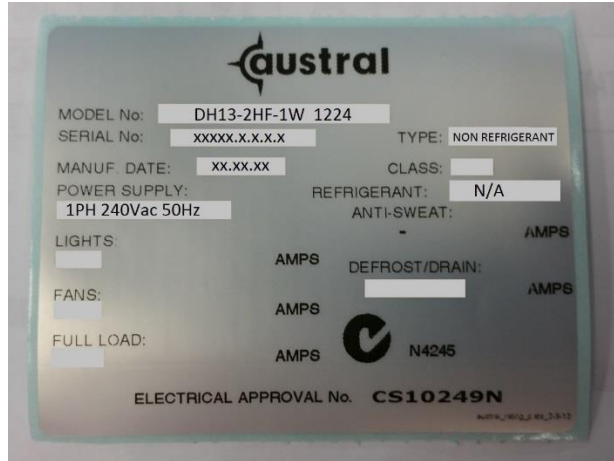

**Fig (15): Rating Plate**

Use only fittings and accessories supplied with the case or approved by Hussmann.



**CAUTION**

Do not climb in or on the case as this may result in personal injury and/or case damage.

## Cleaning and Maintenance

### Daily Checks

- If an alarm system is not part of the refrigeration installation, the temperature of each case should be checked on a daily basis via the thermometer that may be located inside the product area or via another reliable method. The case temperature should be in the range of 60°C - 65°C when stabilised.  
Up to three separate readings may have to be taken to ensure all the case temperature aren't being taken during thermostat cycling.  
If it is consistently outside this range, contact Hussmann or your service contractor.
- Visually check the case for damage or spills and take appropriate remedial action.



**CAUTION**

If any damaged electrical components are identified during inspection isolate case power and contact service contractor.

- Visually inspect drain strainer and drain for any debris which could result in the drains becoming blocked with the possibility of spilling on the floor creating a slip hazard

## Cleaning

A thorough cleaning and service of the case should be carried out by qualified refrigeration and electrical engineers on a six monthly basis. Please contact your service contractor.

Cases should also be cleaned by store staff on at least a weekly basis; some cases may, however, require more frequent cleaning.

## Important Notes

- Do not use hot water on cold glass surfaces as the glass may shatter and cause serious injury.
- Do not use abrasive, solvent, ammonia or oil-based cleaners.
- Do not use steam or a high-pressure system to clean the case.
- When flushing the waste drain, do not use high-pressure water hoses and be careful not to introduce water faster than the waste outlet/drain can drain it.

## Cleaning Procedure

1. Turn off power. Remove stock.



### CAUTION

If case fan power is not isolated then staff should wear hair nets and no jewellery or loose clothing. The fan is protected by wire grill but the possibility exists for items to be caught.

2. Remove all price tickets and any foreign materials from the case.
3. Clean glass or mirrored surfaces with a clean soft cloth and mild glass cleaner.
4. Wipe LAMP with a dry cloth.
5. Wipe down the exterior and interior of the case, paying particular attention to the perforations in the rear panels and the air return grille with a clean soft cloth and mild soapy water.
6. Wipe over with clean dry cloth.
7. Remove the base trays, wash with mild soapy water and rinse.
8. Remove any foreign material from the base of the case.
9. Carefully flush the waste drain with a bucket of water and allow the base to drain.
10. Replace base trays and turn on power.
11. Allow the case to attain correct working temperature (approximately 30 minutes) and restock the shelves.



## Six Monthly Maintenance

A thorough cleaning and maintenance check should be carried out on a six monthly basis by qualified and approved refrigeration and electrical engineers. The following procedures should be undertaken as a minimum.



### CAUTION

Cases should be electrically isolated before carrying out any work that may affect or expose electrical components.

1. Remove and clean the pan decks.
2. Remove any foreign material from the base of the case.
3. Check that all case panels, glass and trims are secure and undamaged.
4. Check for rust or paint damage.
5. Clean the air grilles on the cases.
6. Ensure all cable connections, including screw terminals, earth leads and straps, are secure.
7. Ensure insulation to all electrical components, including fan, (if any) controls, earth terminals and lights, are sound.
8. Carry out electrical safety tests, including earth continuity and insulation resistance.
9. Ensure that the correct fuse (circuit breaker) rating and type is fitted for all circuits.

With case power turned on:

10. Check that all lights and controls are working correctly.
11. Ensure light RCDs (if fitted) are working.

## Operation Servicing

No servicing of Hussmann cases, is to be undertaken by store staff. Please contact your service contractor for all maintenance queries.

# Troubleshooting

ISSUE	POSSIBLE REASON	REMEDIAL ACTIONS
Product temperature is not according to the PED sheet	Store condition is colder than climate class 3 (25°C/60%RH) or below 20°C	Check store air conditioner operation
	Power Supply fault operating at inappropriate settings or conditions	Check power supply and settings.
	Case shelf arrangement has been deviated significantly from original specified setup	Re-do the shelf arrangement as per the original specification
	Doors are not closed.	Ensure doors are kept closed
	None of above	Contact Hussmann
ISSUE	POSSIBLE REASON	REMEDIAL ACTIONS
LAMP are not working	No power supply	Check supply is "on" and light switch is working.
	LAMP fittings	Call technician to check and replace in necessary
	LAMP failed	Replace LAMP

**Table (1) General Troubleshooting**

## Appendixes

- Appendix 1**      **Wiring diagrams** – Supplied with each case.
- Appendix 2**      **Product Engineering Datasheet** – Supplied with each case.
- Appendix 3**      **Setting Table** – Part of PED.
- Appendix 4**      **Attaching case ends**
- Appendix 5**      **Top glass horizontal adjustment**
- Appendix 6**      **Front glass door camber adjustment**

Case ends are normally fitted in the factory; however, they occasionally need to be attached to a case on-site. Use this procedure when an end attaches to a single case and when it is common to two cases.

Ensure that correct and appropriate manual handling techniques are applied when fitting a patch end.

Cases must be sealed before attaching case ends.

To attach a case end

1. Carefully run a knife around the inside rim of the end trim, taking care not to scratch the case end surface, and remove the case end membrane.
2. To assist in screwing in the Lag screws, drill a 6mm hole in the mounting positions shown, using the 10mm diameter fixing hole location. Ensure you do not drill completely through the End. see Fig (16)

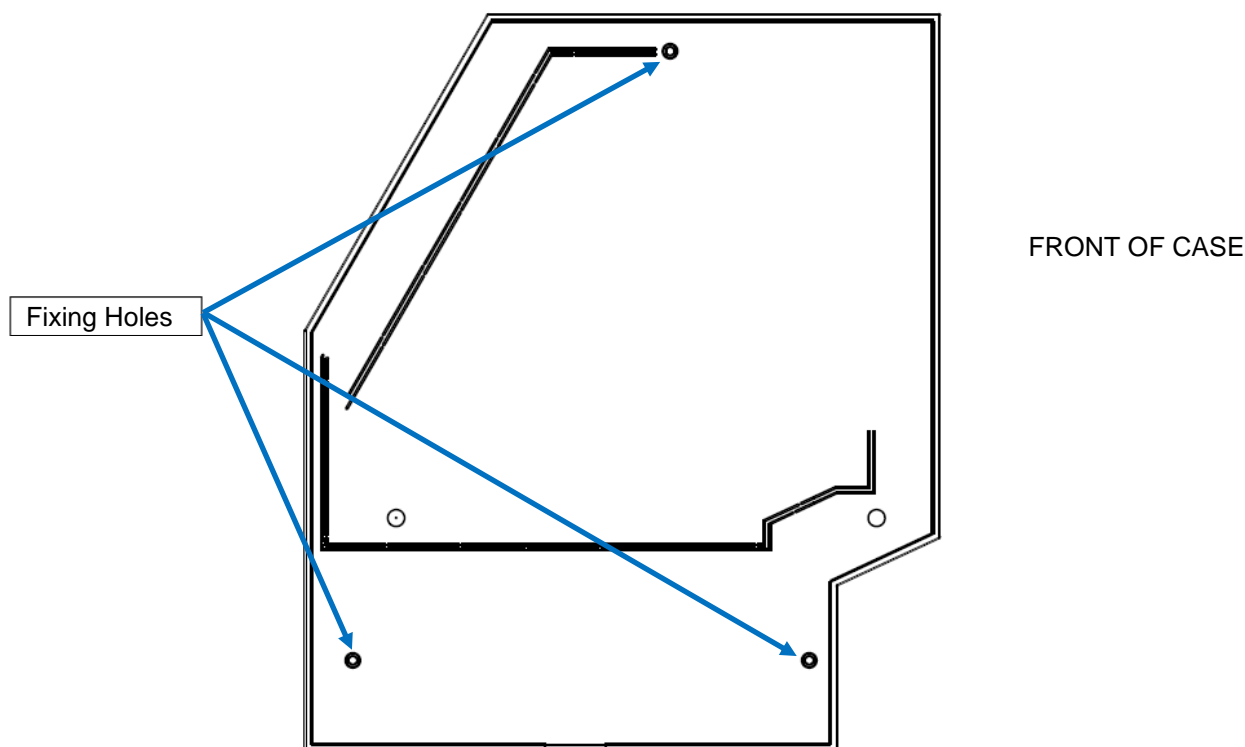

**Fig (16) Drill hole locations**  
(Inside Right hand End shown)

3. If the end is common to 2 cases, repeat step 2 for the other side of the case end.
4. Insert 2 hex nuts onto one of the lag screws, lock nuts together and drive screw through the hole at the top of the case end until the lag is fully embedded in the end.
5. Remove the nuts from the lag screw and repeat step 4 for the remaining holes.
6. Pull up the case ends lightly against the case.
7. Adjust the case so that the end fits comfortably around the canopy and the top of the case and is level, from front to back with the case roof.
8. Secure the case end with the lag screws and bolts
9. Apply either black or white silicon (depending on the interior colour of the case) all the way along the inside joins between the case end and end frame. see Fig (17)

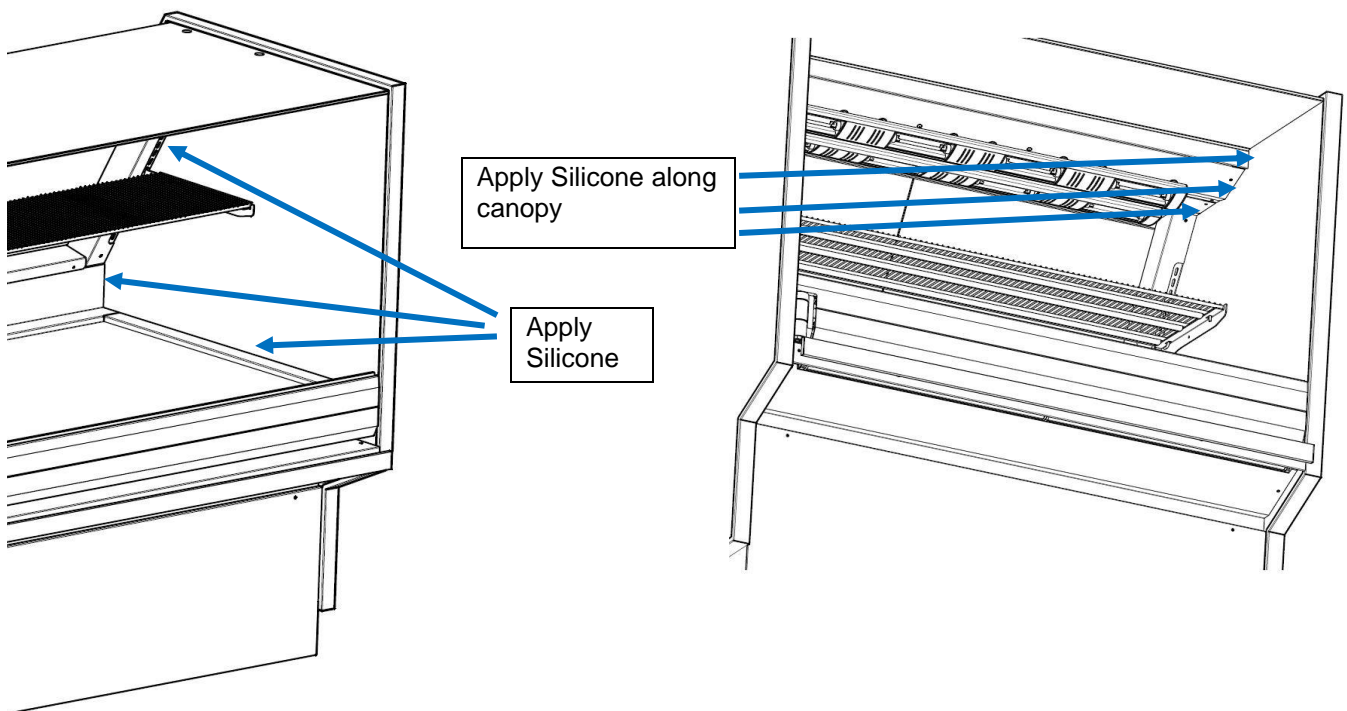

**Fig (17) Silicon ends to case**

10. Applying slight pressure, run your finger along the length of the silicon.
11. Remove all remaining packaging material from the case end and case and trim
12. Attach the end kickplate and, if required, silicon seal to the floor.

## Appendix 5

# Top glass horizontal adjustment

### Summary:

- Top glass may need horizontal adjustment to line up with front door.
- The glass can be adjusted with by moving the neoprene washer supplied under the glass panel.
- The neoprene washer is located under the glass mounting fasteners, between the glass and the top of the case.
- Should the front tolerance between the glass door and the top glass panel be to great the washer would need to be fitted in the rear location.
- Should the tolerance be to close the washer should be moved to the front location.

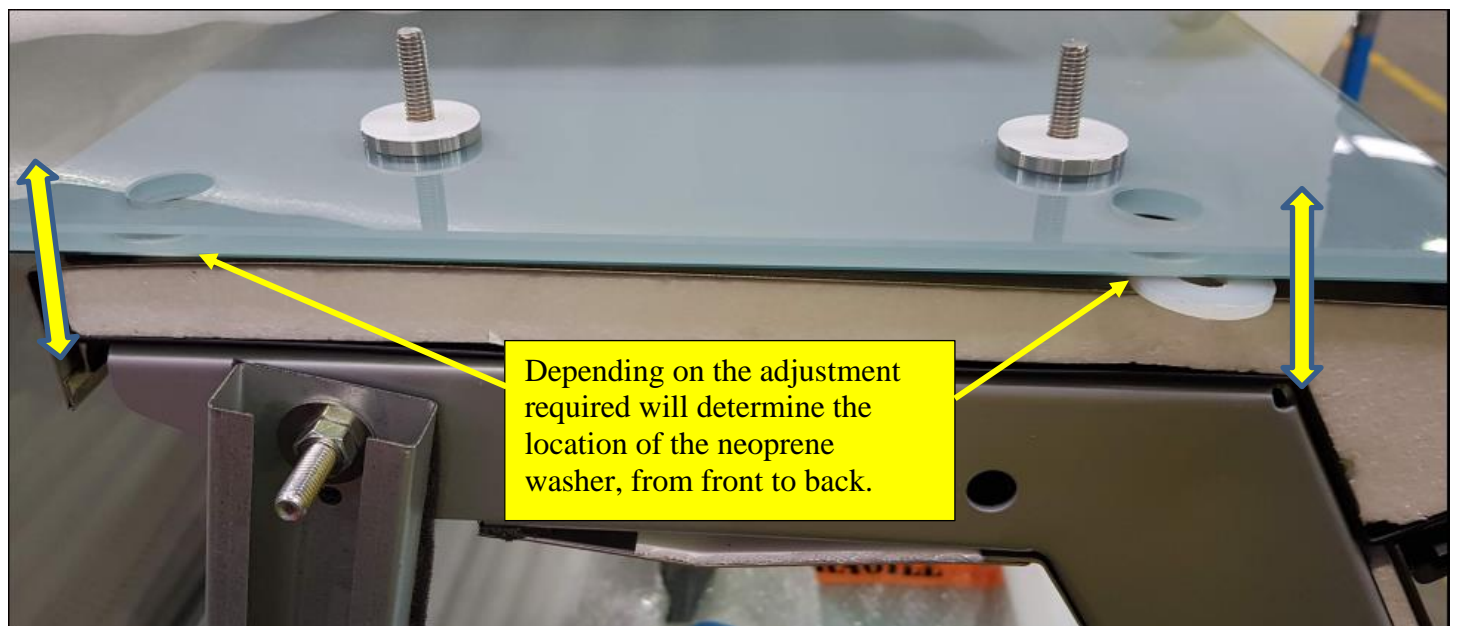

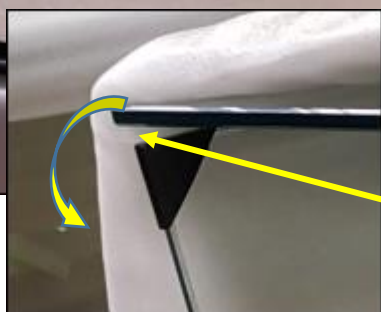
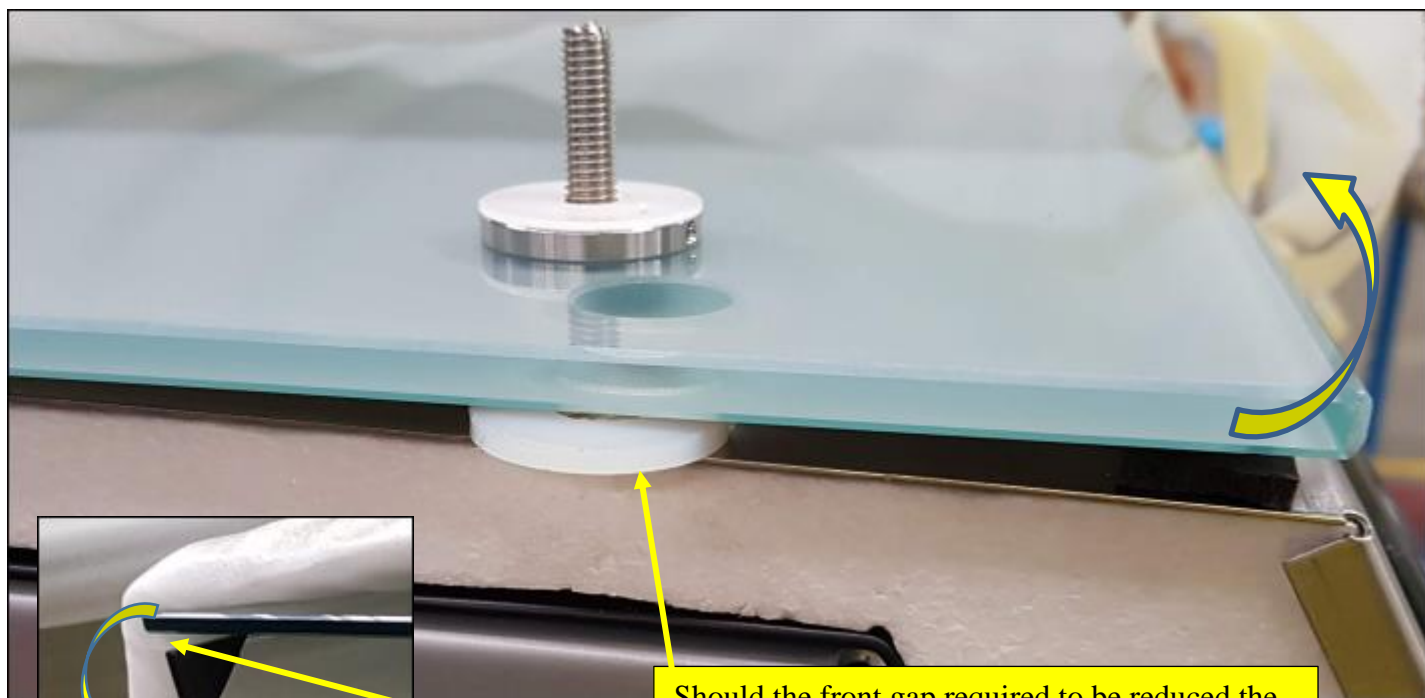

Should the front gap required to be reduced the neoprene washer will need to be fitted under the back glass fastener. This will lift the rear of the glass panel and angle the glass forward reducing the tolerance between the glass to and glass



## Appendix 6

### Front door camber adjustment

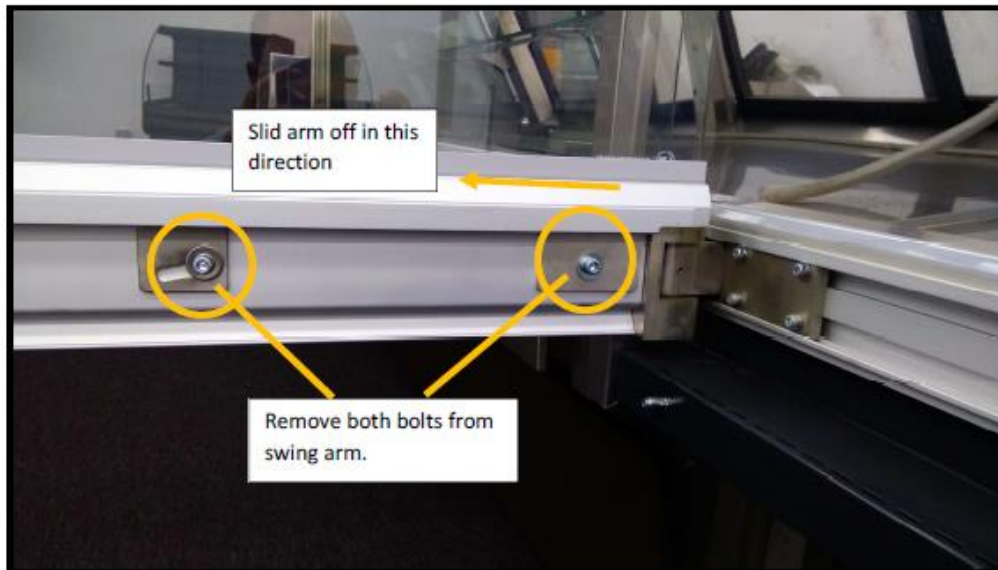

## Appendix 5 Risk analysis

HAZARD	CONTROL MEASURES
<b>Electrical -</b> Replacement of electrical components	Request a service call. Electrically isolate cases before works
<b>Ergonomic -</b> Moving/ positioning/ adjusting cases	Staff must be trained in the correct procedures for setting up cases and ergonomic practices. PPE must be worn
<b>Falling -</b> Connecting sensor probe wiring during installation	Use of barriers & fall arrest systems as appropriate & in accordance with State & Territory Legislation. Safe working at heights
<b>Entanglement -</b> Contact with fans when cleaning	Electrically isolate cases before work is carried out. Staff training,
<b>Cuts and stabbing -</b> Potential for cuts from broken fluorescent tube or during tube replacement	Electrically isolate cases. Staff not to replace tubes. Call service provider. PPE must be worn.
<b>Electrical -</b> Potential for electric shock when cleaning electrical fittings and components	Electrically isolate cases before work is carried out. Staff training, RCD. Keep electrical connections dry at all times.
<b>Falling -</b> Climbing on shelves	Staff must be trained in OH&S procedures. MUST not climb on shelves or cases.
<b>Crushing -</b> Hands or fingers may become pinched or crushed during the positioning of base trays, shelves & stock	Staff must be trained in the correct procedures for setting up cases and ergonomic practices
<b>Slipping -</b> Drain may leak or become blocked causing water spillage	Visual Inspection and regular maintenance. Request service call when necessary.
<b>Cuts and stabbing -</b> Potential for cuts caused by damaged or missing parts	Visual Inspection and regular maintenance. Request service call when necessary. PPE must be worn when handling broken or damaged parts.
<b>Ergonomic -</b> Stretching during the cleaning of the case and positioning of stock and shelves leading to strains and sprains	Staff must be trained in the correct procedures for cleaning cases & ergonomic practices. Cleaning tools which reduce the need for stretching should be used.
<b>Slipping -</b> Surfaces may become slippery due to spillage from the case during operation or cleaning	Visual Inspection. Appropriate remedial action.
<b>Cuts and stabbing -</b> Potential for cuts caused by sharp edges & evaporator coil during cleaning	PPE must be worn by staff
<b>Cuts and stabbing -</b> Cleaning cold glass surfaces with hot water	Staff must be trained in the correct procedures for cleaning cases and ergonomic practices
<b>Crushing -</b> fingers, hands or body between doors	Operators to always open and close doors using handles provided, ensuring the area is clear of other persons.
<b>Electrical -</b> electrical connections in cases	Electrically isolate cases before work begins. Must be carried out by a service provider. Staff training.

Table (3) Risk analysis



## Appendix 6 Controller

LTR-5 Series controller from LAE are used for DH series.

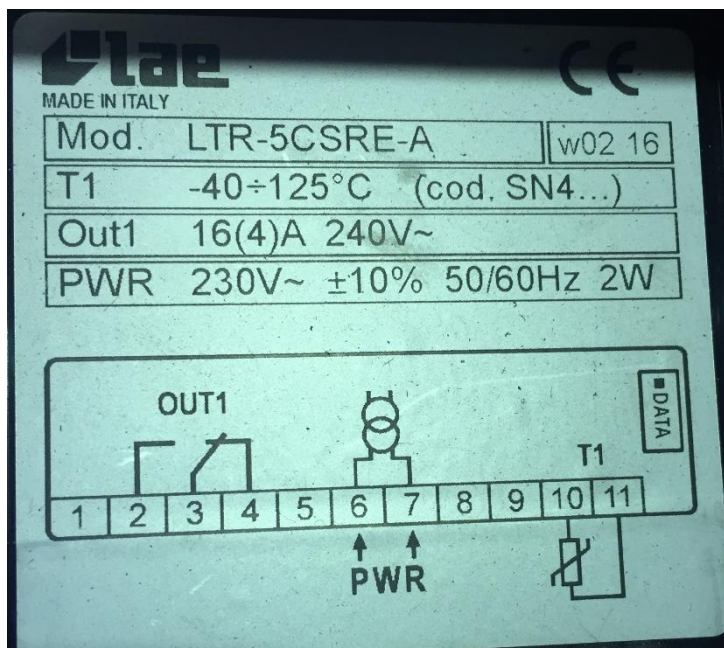

FEATURES	DESCRIPTION
Sensor type	NTC
Temperature range	-40~125 degree °C
Accuracy range	<+-0.3 °C within -40~100 °C
Relay outputs	16(4)A 240Vac
Power supply	230Vac ±10% 50~60Hz 2W
Operation condition	-10~50 °C

Main Setting Index	DESCRIPTION
SPL	Minimum setpoint
SPH	Maximum setpoint
ISP	Case setpoint
1HY	Control hysteresis
SCL	Readout scale

For the manufacturer setting value please refer to PED sheet for each case model.

## Appendix 7 Warranty

The information in this manual is for “Qualified Persons Only”. It is **NOT** an Installation Guide for “**NON Qualified Persons**”.

To obtain warranty information or other support, contact your nearest Hussmann representative.

Please include the following:

- Customer site location.
- Cabinet model & serial number of product.
- Reason for warranty.