

HOT

# RHR

2 TIER - SELF SERVICE DISPLAY CABINET



ENHANCED ENERGY EFFICIENCY  
& VERSATILITY

**HUSSMANN®**

**PRODUCT BENEFITS**

- Ergonomic design for easy access
- Multi level island cabinet with hexagonal footprint
- Suitable for merchandising packaged hot food
- Ability to merchandise up to 48 packaged chickens presented in single layers
- Low Total Energy Consumption (TEC)
- Product temperature compliance
- Simple to install and maintain

**STANDARD FEATURES**

- Full stainless steel interior
- Powder coated front exterior panels
- Top tier 275mm, base 460mm
- Electric box rear lower access
- Halogen lighting on both levels
- Radiant heat on both levels
- Poly carbonate & acrylic heat guards
- Temperature indicators
- Fixed base
- Plastic bumper
- Protected evaporator assembly fitted with valve
- Digital thermometer display fitted
- Promotional light box on the top of the canopy
- Lockable 125 mm castors (to allow mobility)
- Power supply through canopy or base

**CUSTOMISATIONS****Other**

- Technology solutions
- Electronic shelf labels

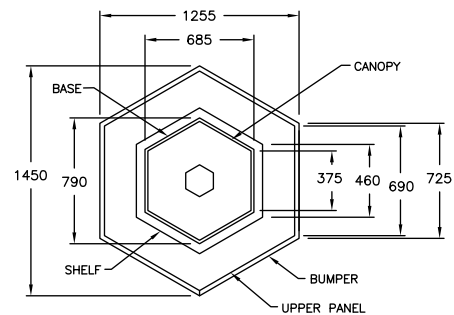
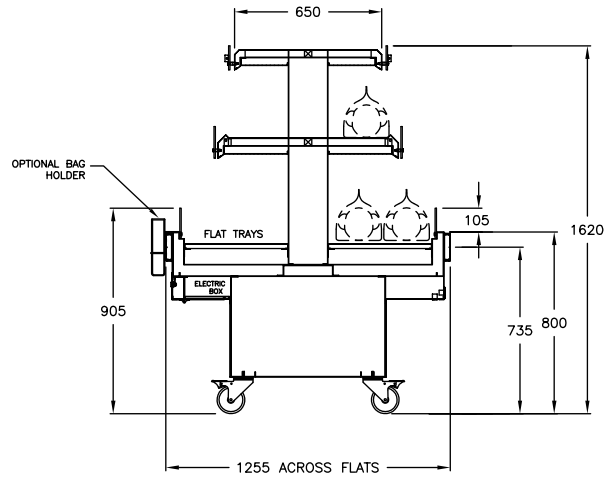
**AVAILABLE LENGTHS**

Excluding Ends: 1255

**AVAILABLE DEPTHS**

Standard: 1450

TEMPERATURE  
CLASS

HOT



(+65 / +80 ° C)

**AVAILABLE COLOURS****Additional Information**

All Dimensions shown in Millimetres (mm) unless otherwise stated. Dimensions and features are subject to change. Please obtain current technical information prior to order confirmation.

**NOTE:** We reserve the right to change or revise specifications and product design in connection with any feature of our products. Such changes do not entitle the buyer to corresponding changes, improvements, additions or replacements for equipment previously sold or Shipped.



© 2020 Hussmann Corporation - Version - V.1.0

**McAlpine Hussmann**

2-6 Niall Burgess Road, Mt Wellington, Auckland 1060, New Zealand

ph. +64 9526 6800

w. www.mcalpinehussmann.co.nz

**MCALPINE HUSSMANN**