

HOT

KH14

2 TIER - SELF SERVICE DISPLAY CABINET

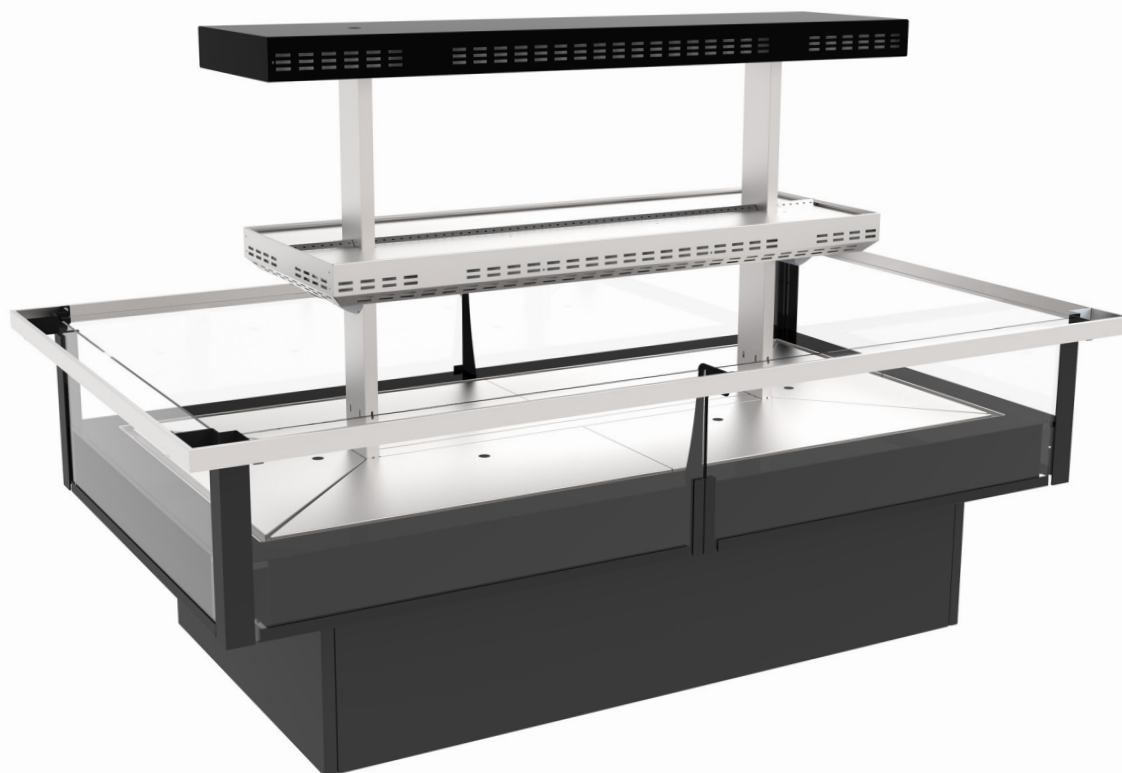

ENHANCED ENERGY EFFICIENCY
& VERSATILITY

HUSSmann®

PRODUCT BENEFITS

- Ergonomic design for easy access
- Multi level island cabinet with rectangular footprint
- Suitable for merchandising packaged hot food
- Low Total Energy Consumption (TEC)
- Product temperature compliance
- Simple to install and maintain

STANDARD FEATURES

- Full stainless steel interior
- Powder coated canopy & front exterior panels
- Electrical connection on top
- Halogen lighting on both levels
- Radiant heat on both levels
- Fixed base with height adjustable base trays (flat or angled)

CUSTOMISATIONS**Accessories**

- Utensil holder

Bumper

- Single stainless steel bumper rail

Other

- Technology solutions
- Electronic shelf labels

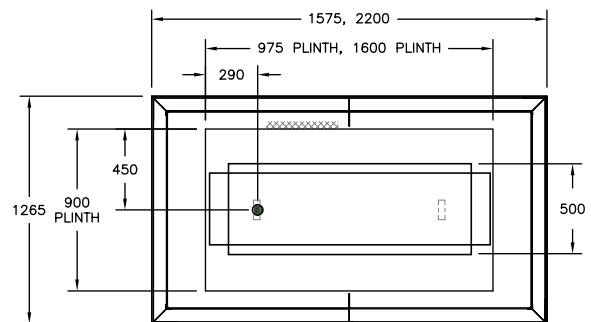
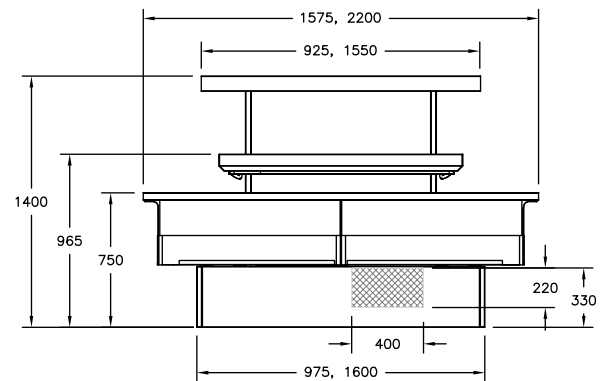
**AVAILABLE LENGTHS**

Standard: 1575, 2200

TEMPERATURE CLASS

HOT



(+65 ° C)

AVAILABLE DEPTHS

Standard: 1265

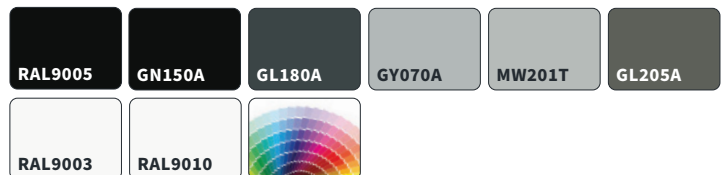
AVAILABLE COLOURS**Additional Information**

All Dimensions shown in Millimetres (mm) unless otherwise stated. Dimensions and features are subject to change. Please obtain current technical information prior to order confirmation.

NOTE: We reserve the right to change or revise specifications and product design in connection with any feature of our products. Such changes do not entitle the buyer to corresponding changes, improvements, additions or replacements for equipment previously sold or Shipped.



© 2020 Hussmann Corporation - Version - V.1.0

McAlpine Hussmann

2-6 Niall Burgess Road, Mt Wellington, Auckland 1060, New Zealand

ph. +64 9526 6800

w. www.mcalpinehussmann.co.nz

MCALPINE HUSSMANN®