

SpeCialit y

# AME12S

Self C ont ained iSl and Mer Chandi Ser



ENHANCED ENERGY EFFICIENCY  
& VERSATILITY

**HUSSmann®**

## PRODUCT BENEFITS

- Ergonomic design for easy access
- Optimised display with LED lighting
- Low Total Energy Consumption (TEC)
- Longer merchandise shelf life
- Product temperature compliance
- Simple to install and maintain
- Designed for modular configurations
- Suitable for Drinks, Specialty, Bakery and Grab and Go merchandising

## STANDARD FEATURES

- Internal and external powder coating
- Single row of 4000K LED canopy lighting
- 1 row of 275mm glass lit shelves
- Angled base deck 425mm
- Ticket strips
- Air return grill
- Galvanised base
- Evaporator assembly fitted with valve
- Condensing Unit featuring Reverse Fan Technology
- EC fan motors
- Digital display fitted
- Alarm probe fitted with conduit and draw wire

## CUSTOMISATIONS

### Shelving & Base Shelf

- Glass shelving included

### Lighting

- Jamicon 4000k

### Ends

- Included

### Bumper

- Stainless steel bumper (single or double rail)
- Timber and Tiling cladding

### Other

- Technology solutions
- Electronic shelf labels

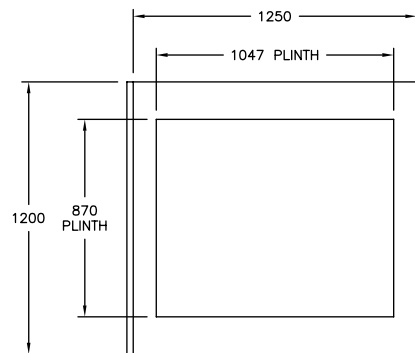
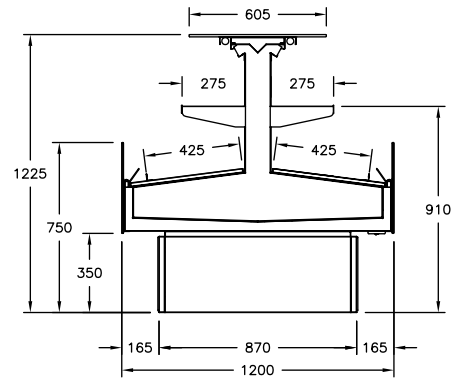

## AVAILABLE WIDTHS

Excluding Ends: 1250

## AVAILABLE DEPTHS

AME12S Standard: 1200

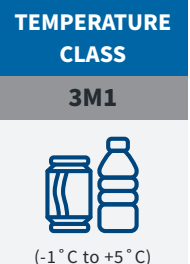

## AVAILABLE COLOURS

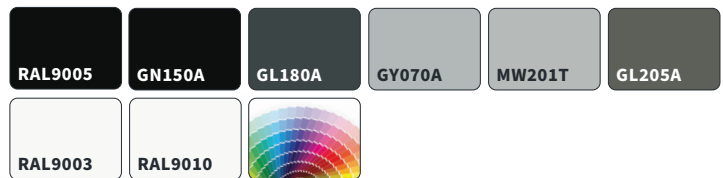

### Additional Information

All Dimensions shown in Millimetres (mm) unless otherwise stated. Dimensions and features are subject to change. Please obtain current technical information prior to order confirmation.

**NOTE:** We reserve the right to change or revise specifications and product design in connection with any feature of our products. Such changes do not entitle the buyer to corresponding changes, improvements, additions or replacements for equipment previously sold or Shipped.



© 2020 Hussmann Corporation - Version - V.1.0

## McAlpine Hussmann

2-6 Niall Burgess Road, Mt Wellington, Auckland 1060, New Zealand

ph. +64 9526 6800

w. www.mcalpinehussmann.co.nz

