

SELF CONTAINED

# ARCH PLUS

DUAL TEMP VERTICAL TOP MOUNTED CABINETS



ENHANCED ENERGY EFFICIENCY  
& VERSATILITY

**HUSSmann**<sup>®</sup>

## PRODUCT BENEFITS

- Modular section seamlessly integrates with the base arch series
- Move both base and top section without disassembly
- Ergonomic design for easy product access
- Flexible shelving configurations to optimise merchandising
- Best visual impact for products with energy efficient LED lighting
- Low Total Energy Consumption to save on total energy costs
- Ensured product temperature compliance tested
- Minimal footprint through optimisation of the vertical space
- Maximised vertical display area
- Reinforced shelving to suit varied product weight
- Environmentally sustainable design using natural refrigerant
- Easy plug-in on-site installation
- Anti-condensation coating on doors for improved product visibility
- Anti-reflective, low E-coated glass for improved temperature control and visibility
- Flexible dual temperature cabinet (LT and MT) that easily changes from freezer to chiller to provide optimised merchandising to meet customer demand
- Accessible water drainage opening for easy cleaning

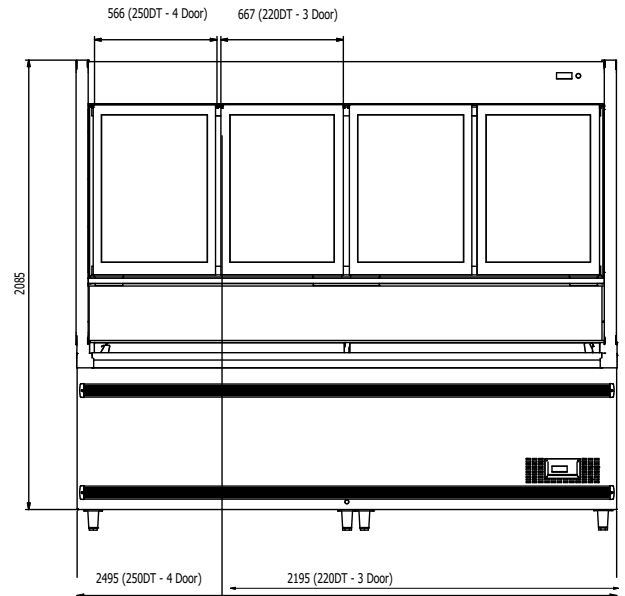

## STANDARD FEATURES

- External and internal food grade plasticised metal sheet finish
- Vertical mounted 5700K LED light
- Ticket strips
- Ventilated refrigeration system with copper evaporator
- Digital controller with temperature display
- Ventilated condensing unit
- Glass, self-closing hinged doors
- Automatic hot-gas defrost
- Shelves configuration: 2 shelf rows plus base
- Refrigerant: R290
- EC fan motors

## CUSTOMISATIONS

### Shelving & Base Shelf

- Additional shelves and brackets

### Mirror Close-Off

- Option to substitute lower mirror for painted steel plate

### Other

- External and internal colours available on request

## AVAILABLE LENGTHS

2200, 2500

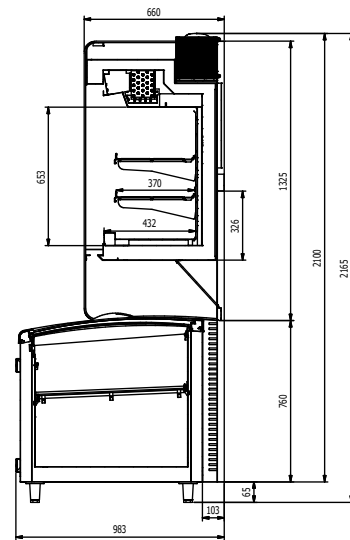

### TEMPERATURE CLASS

3M1

3L1



(-1 °C to +5 °C)



(-18 °C to -15 °C)

### TECHNICAL DATA

CODE	Standard Depth 630mm Standard Height 1315mm	ARCH PLUS220- DT	ARCH PLUS250- DT
Total Length (mm)		2200	2500
Net Volume (L)		415	554
Display Area (m <sup>2</sup> )		1.00	1.11

#### Additional Information

All Dimensions shown in Millimetres (mm) unless otherwise stated. Dimensions and features are subject to change. Please obtain current technical information prior to order confirmation.

**NOTE:** We reserve the right to change or revise specifications and product design in connection with any feature of our products. Such changes do not entitle the buyer to corresponding changes, improvements, additions or replacements for equipment previously sold or Shipped.

© 2021 Hussmann Corporation - Version - V.1.0

## McAlpine Hussmann

2-6 Niall Burgess Road, Mt Wellington, Auckland 1060, New Zealand

ph. +64 9526 6800

e. commercialnz@hussmann.com

w. www.mcalpinehussmann.co.nz

