

SPECIALTY

# ID3BL-SSM

SELF-SERVICE SHELLFISH DISPLAY CABINET

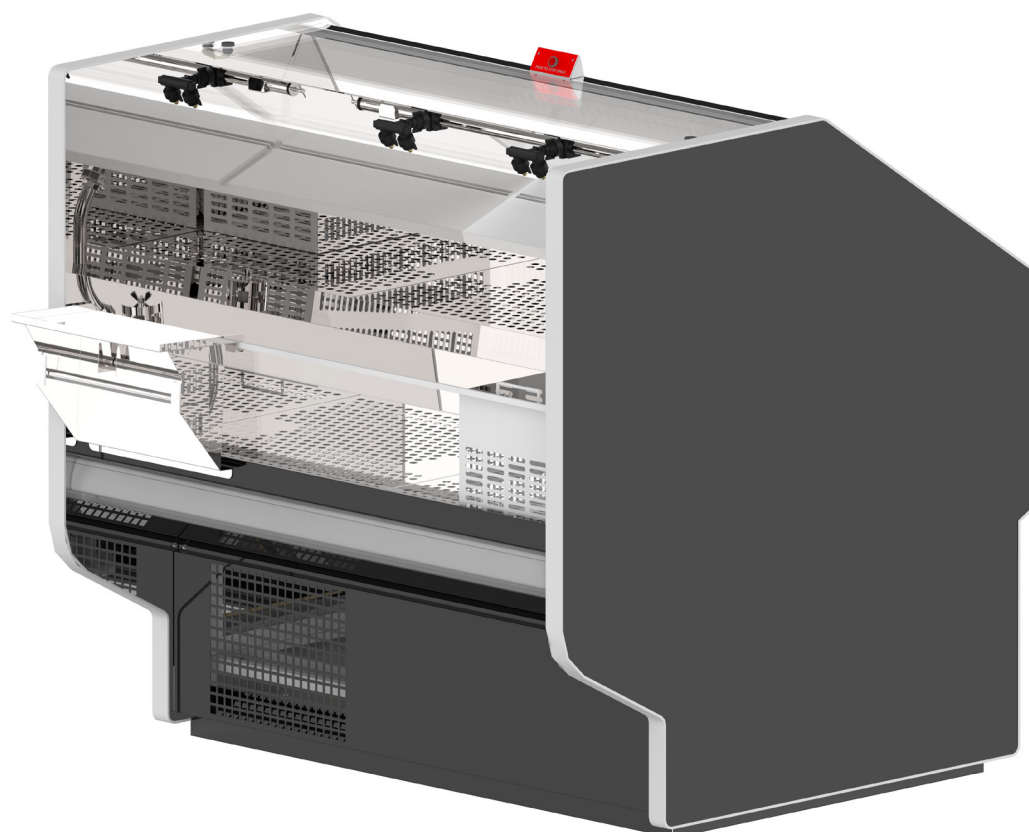

ENHANCED ENERGY EFFICIENCY  
& VERSATILITY

**HUSSMANN**<sup>®</sup>  
A Panasonic Company

## PRODUCT BENEFITS

- Overhead water spray for enhanced product freshness
- Maximised product visibility
- Longer merchandise shelf life
- Product temperature compliance

## STANDARD FEATURES

- Large rear sliding doors
- Self serve
- Rear control access
- External stainless steel panels
- Stainless steel internal panels
- Stainless steel pressure foamed tub
- Toughened front glass
- Stainless canopy
- Black vinyl cart bumper
- Canopy lighting

## CUSTOMISATIONS

### Shelving & Base Shelf

- Stainless steel dividers
- Stainless steel basket for other shellfish

### Ends

- Bright stainless or view ends

### Other

- Front access for controls
- Tong holder
- Canopy mounted bag- roll holder
- Front mounted bag roll holder
- General power outlet
- Painted exterior on stainless steel panels

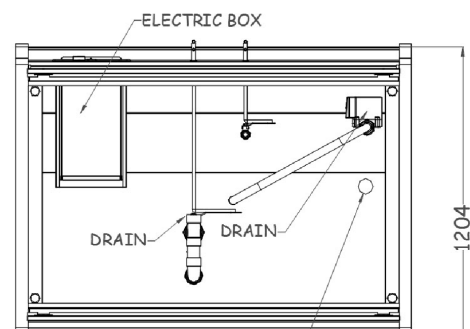
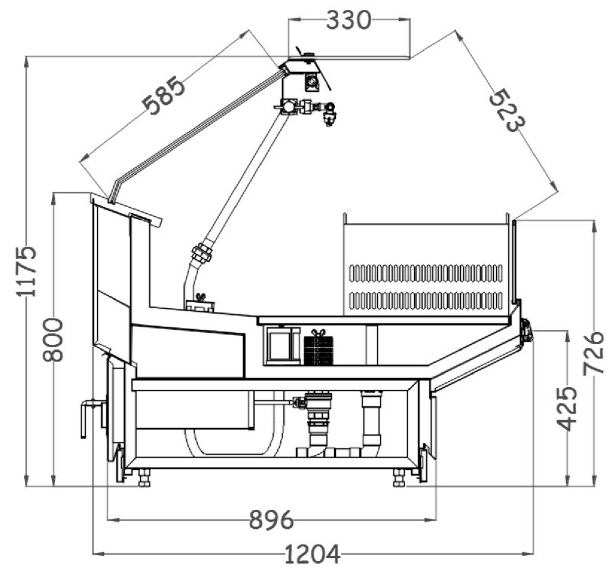

### TECHNICAL DATA

Model Length (mm)	900	1250	1875

## AVAILABLE COLOURS

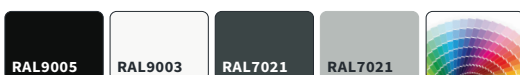

### Additional Information

All Dimensions shown in Millimetres (mm) unless otherwise stated. Dimensions and features are subject to change. Please obtain current technical information prior to order confirmation. Length mentioned in Technical Data are exclusive of Side Panel

**NOTE:** We reserve the right to change or revise specifications and product design in connection with any feature of our products. Such changes do not entitle the buyer to corresponding changes, improvements, additions or replacements for equipment previously sold or Shipped.

### TEMPERATURE CLASS

3M1



(-1 °C to +5 °C)

## McAlpine Hussmann

2-6 Niall Burgess Road, Mt Wellington, Auckland 1060, New Zealand

ph. +64 9526 6800

e. [commercialnz@hussmann.com](mailto:commercialnz@hussmann.com)

w. [www.mcalpinehussmann.co.nz](http://www.mcalpinehussmann.co.nz)